

angled view with clamping bracket

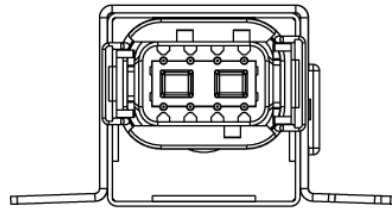

connector view with clamping bracket

DESCRIPTION

The Prop CAN 2CH DTM with CAN bus is used to continuously control two consumers and in particular to control proportional valves. Due to its two outputs, it implements double functionality with the same installation space. In combination with the DEUTSCH DTM connector, it offers you robust quality and is ideally suited for extreme environmental conditions.

TECHNICAL DATA

Housing	Waterproof potted plastic housing; Plastic PA66 GF30
Connector	DEUTSCH DTM04-08PA
Weight	71 g
Temperature range acc. to ISO 16750-4	-40 °C...+85 °C
Environmental protection acc. to ISO 20653	IP6K8 with correct mounting direction (plug down)
Current consumption	30 mA
Fuse protection	see max. switching current
Total inputs and outputs	3 (1 analog input, 2 outputs [PWM capable, integrated current measurement INA])
Inputs	Analog input 0...33 V Frequency input
Outputs	Configurable as: Digital, positive switching PWM output
Supply voltage	7...32 V (Code B at 12 V, Code E at 24 V acc. to ISO 16750-2)
Supply protection	≥ 33 V
Quiescent current	30 µA at 12 V 80 µA at 24 V measured with DO_EN_KL30=0
Reverse polarity protection	yes
CAN Interfaces	ISO 11898-2 and ISO 11898-5 capable CAN bus transceiver

REGULATORY APPROVALS AND TESTING

E1 approval 10 R - 06 9865

Electrical tests

Acc. to ISO 16750-2 or -4:

Long term overvoltage at T_{max} -20 °C

Superimposed alternating voltage

Starting profile

Load Dump Test B at 24 V ($R_i = 4 \Omega$)

Reversed voltage

Short circuit

Storage test at T_{min} and T_{max}

Operation test at T_{min} and T_{max}

Acc. to ISO 7637-2:

Pulse 1, 2a, 2b, 3a, 3b

SOFTWARE/PROGRAMMING

Programming System

MRS APPLICS STUDIO

The Applics Studio is the new development and tool platform for our assemblies. Program your MRS controls quickly and easily with our stand-alone software. The focus is on your application.

INPUT FEATURES - SUMMARY

Pin 8 (C)			Pin 5 (KL15)		
	Programmable as analog or digital input			Programmable as analog or digital input	
	Resolution	12 Bit		Resolution	12 Bit
Voltage input 0...33 V (see A)	Input resistance	42 kΩ	Voltage input 0...33 V (see A)	Input resistance	48 kΩ
	Input frequency ¹	$f_g^1 = 375 \text{ Hz}$		Input frequency ¹	$f_g^1 = 330 \text{ Hz}$
	Accuracy	$\leq 3 \%$		Accuracy	$\leq 3 \%$
Frequency input (see B)	Input resistance	42 kΩ			
		up to 400 Hz			
	Accuracy	$\leq 3 \%$			
	Turn-on threshold	$3.4 \text{ V} \pm 0,3 \text{ V}$			
	Turn-off threshold	$1.6 \text{ V} \pm 0,3 \text{ V}$			

¹ Cutoff frequency (-3 dB)

OUTPUT FEATURES - SUMMARY

Pin 2, 3 (87A, 87)	Protective circuit for inductive loads	integrated
	Wire fault diagnostics	via current sense
	Short circuit diagnostics	via current sense
Digital, positive switching (high side; see C) incl. INA-current sense	Switching voltage	7...32 V
	Switching current	see below
PWM output (see C)	Output frequency	10 Hz...1 kHz
	max. switching current	see below
Short circuit resistance against GND and U_B	Shutdown of the outputs controlled by output driver	

LOAD TESTS OF HSD-OUTPUTS

Test without PWM	Test no.	Load	Test parameter	Test with PWM	Test no.	PWM	Load	Test parameter
	1	2.77 A per output	at 85 °C and $U_B = 28 \text{ V}$		1	200 Hz	1.6 A per output	at 85 °C and $U_B = 28 \text{ V}$
					2	500 Hz	0.9 A per output	at 85 °C and $U_B = 28 \text{ V}$
					3	200 Hz	2.4 A per output	at 23 °C and $U_B = 28 \text{ V}$
					4	500 Hz	1.5 A per output	at 23 °C and $U_B = 28 \text{ V}$

PIN ASSIGNMENT POWER SUPPLY AND INTERFACES

Pin	Description	Pin	Description
1	KL31 / GND	6	CAN-L
4	KL30 / Supply voltage	7	CAN-H
5	KL15 / Ignition		

PIN ASSIGNMENT INPUTS AND OUTPUTS

Pin	Signal	Description	Pin	Signal	Description
2	DO_PWM_X87A PWM_X87A AI_I_HSD_X87A AI_INA_X87A	Digital output X87A with PWM-option and HSD current sense or INA 293 current sense	4	AI_KL30 DO_EN_KL30	KL30 measurement 0...33 V with activation option (standard value = 0)
3	DO_PWM_X87 PWM_X87 AI_I_HSD_X87 AI_INA_X87	Digital output X87 with PWM-option and HSD current sense or INA 293 current sense	5	AI_KL15	Analog input KL15 0...33 V
			8	AI_C FREQ_C	Analog input C 0...33 V or frequency input

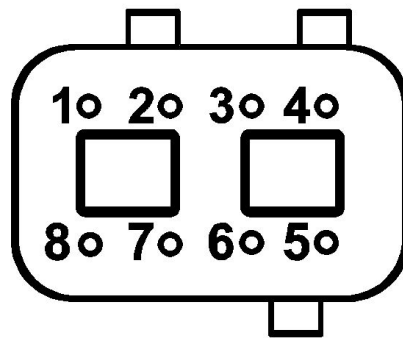

pin assignment - bottom view

PIN - OVERVIEW

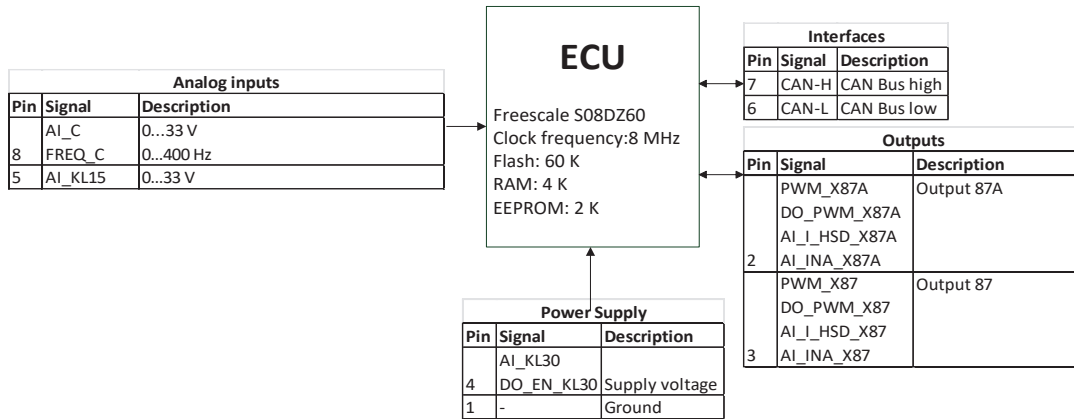

BLOCK FUNCTION DIAGRAM

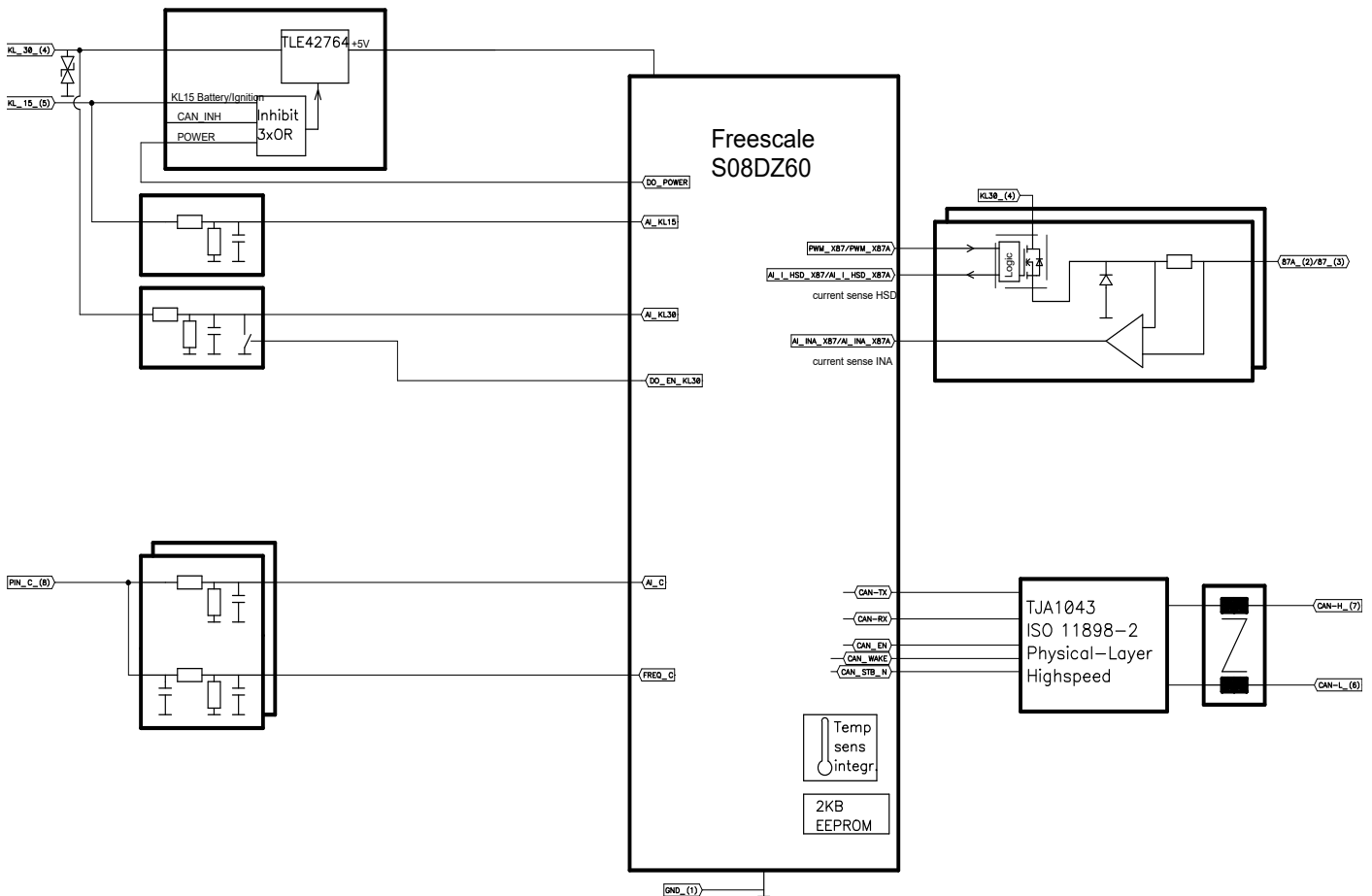

TECHNICAL DRAWING IN MM [INCH], TOLERANCES ACCORDING TO ISO 2768-1 V

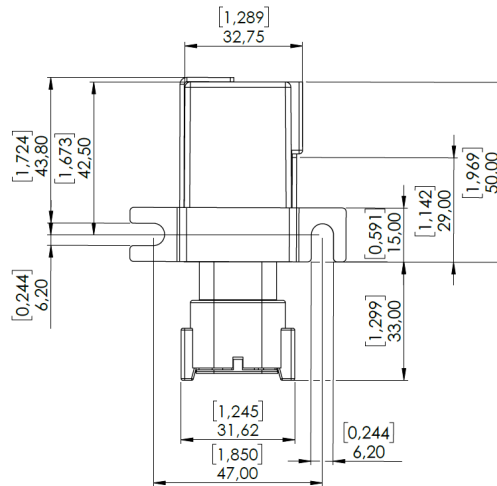

front view

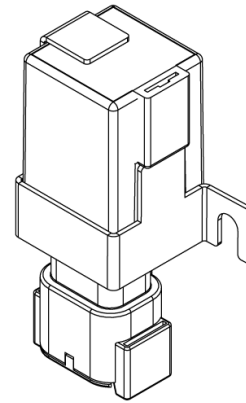

angled view

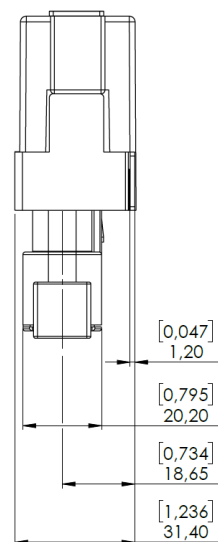

side view

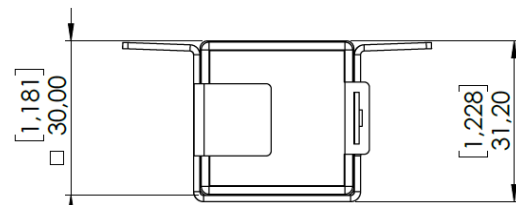

top view

ASSEMBLY VARIANTS AND ORDERING INFORMATION

Drawing no.	Inputs numbering		Outputs numbering	CAN		Wake up sources	Remarks
	A voltage 0...33 V	B frequency 0...400 Hz		High-Speed	High-Speed with 120Ω termination re- sistance		
1.168.900.0000	5, 8	8	C HSD-Outputs with current sense optio- nally via HSD or INA 2, 3	X		CAN, KL15, DO_POWER	

ACCESSORIES

Description	Order number
Programming tool MRS Applies Studio	1.100.200.01
Socket package DTM04-08	301995
Mounting bracket	502693
PCAN-USB Interface	105358
Housing bracket	1.017.080.00
Cable set to program DTM modules	302379

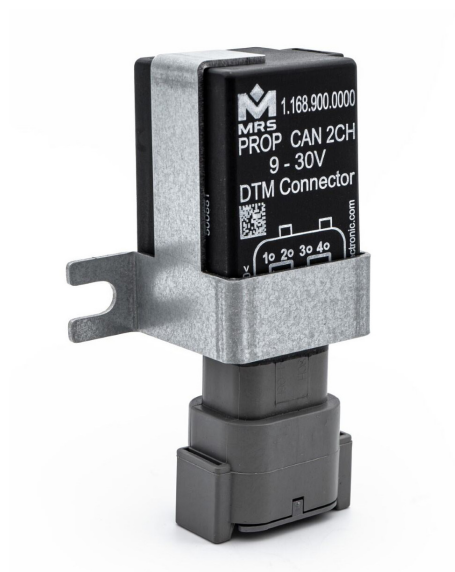

MANUFACTURER

MRS Electronic GmbH & Co. KG
Klaus-Gutsch-Str. 7
78628 Rottweil
Germany

NOTES ON WIRING AND CABLE ROUTING

The control must be protected against overload (see performance data)

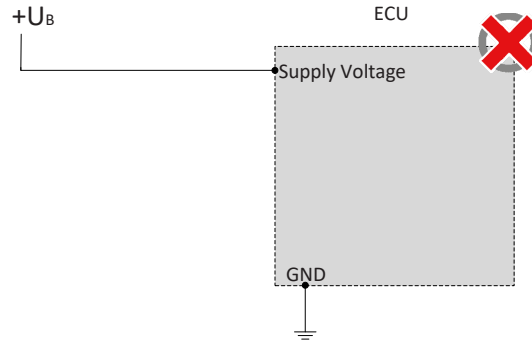
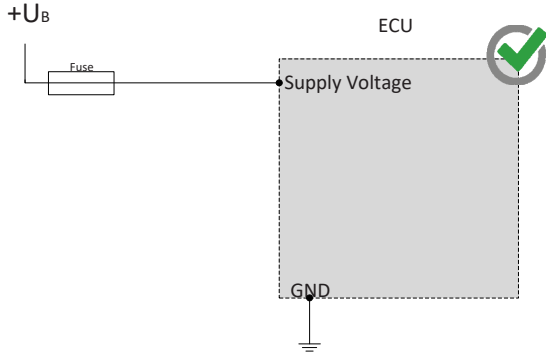

PWM- and higside outputs may only be switched to ground.

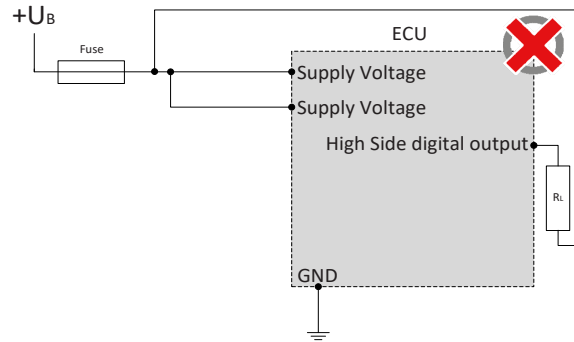
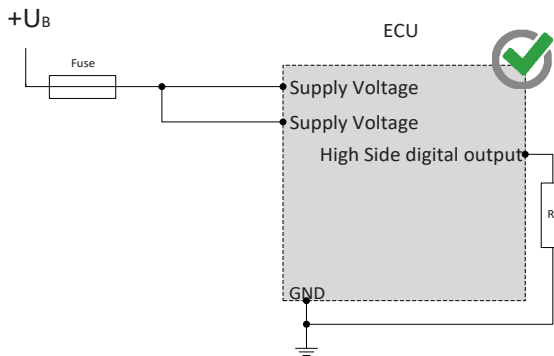
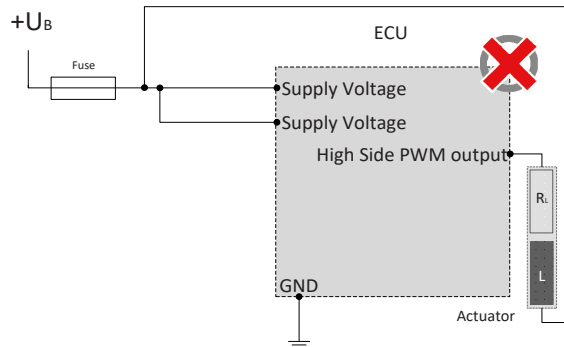
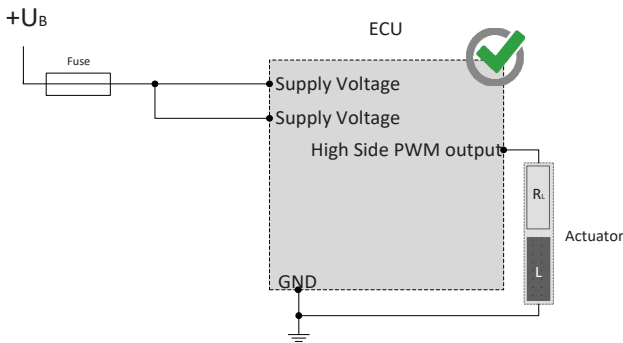

CAN bus communication is the main communication between the control unit and the vehicle. Therefore, connect the CAN bus with special care and check the correct communication with the vehicle to avoid undesired behavior.

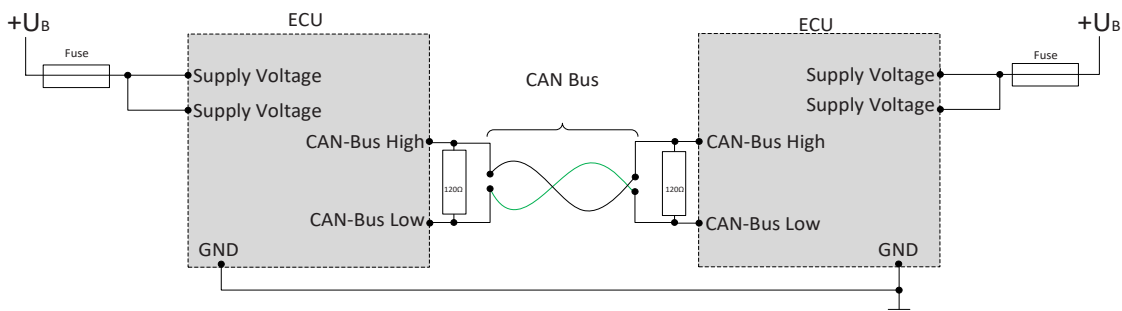

SAFETY AND INSTALLATION INFORMATION

It is essential to read the instructions in full thoroughly before working with the device.

Please note and comply with the instructions in the operating instructions and the information in the device data sheet, see www.mrs-electronic.de

Staff qualification: Only staff with the appropriate qualifications may work on this device or in its proximity.

SAFETY



WARNING! Danger as a result of a malfunction of the entire system.

Unforeseen reactions or malfunctions of the entire system may jeopardise the safety of people or the machine.

- Ensure that the device is equipped with the correct software and that the wiring and settings on the hardware are appropriate.



WARNING! Danger as a result of unprotected moving components.

Unforeseen dangers may occur from the entire system when putting the device into operation and maintaining it.

- Switch the entire system off before carrying out any work and prevent it from unintentionally switching back on.
- Before putting the device into operation, ensure that the entire system and parts of the system are safe.
- The device should never be connected or separated under load or voltage.



CAUTION! Risk of burns from the housing.

The temperature of the device housing may be elevated.

- Do not touch the housing and let all system components cool before working on the system.

PROPER USE

The device is used to control or switch one or more electrical systems or sub-systems in motor vehicles and machines and may only be used for this purpose. The device may only be used in an industrial setting.



WARNING! Danger caused by incorrect use.

The device is only intended for use in motor vehicles and machines.

- Use in safety-related system parts for personal protection is not permitted.
- Do not use the device in areas where there is a risk of explosion.

Correct use:

- operating the device within the operating areas specified and approved in the associated data sheet.
- strict compliance with these instructions and no other actions which may jeopardise the safety of individuals or the functionality of the device.

Obligations of the manufacturer of entire systems

It is necessary to ensure that only functional devices are used. If devices fail or malfunction, they must be replaced immediately.

System developments, installation and the putting into operation of electrical systems may only be carried out by trained and experienced staff who are sufficiently familiar with the handling of the components used and the entire system.

It is necessary to ensure that the wiring and programming of the device does not lead to safety-related malfunctions of the entire system in the event of a failure or a malfunction. System behaviour of this type can lead to a danger to life or high levels of material damage.

The manufacturer of the entire system is responsible for the correct connection of the entire periphery (e.g. cable cross sections, correct selection/connection of sensors/actuators).

Opening the device, making changes to the device and carrying out repairs are all prohibited. Changes or repairs made to the cabling can lead to dangerous malfunctions. Repairs may only be carried out by MRS.

Installation

The installation location must be selected so the device is exposed to as low a mechanical and thermal load as possible. The device may not be exposed to any chemical loads.

Install the device in such a manner that the plugs point downwards. This means condensation can flow off the device. Single seals on the cables/leads must be used to ensure that no water gets into the device.

Putting into operation

The device may only be put into operation by qualified staff. This may only occur when the status of the entire system corresponds to the applicable guidelines and regulations.

FAULT CORRECTION AND MAINTENANCE



NOTE The device is maintenance-free and may not be opened.

- If the device has damage to the housing, latches, seals or flat plugs, it must be taken out of operation.

Fault correction and cleaning work may only be carried out with the power turned off. Remove the device to correct faults and to clean it.

Check the integrity of the housing and all flat plugs, connections and pins for mechanical damage, damage caused by overheating, insulation damage and corrosion. In the event of faulty switching, check the software, switches and settings.

Do not clean the device with high pressure cleaners or steam jets. Do not use aggressive solvents or abrasive substances.