

Mounting view (depending on assembly)

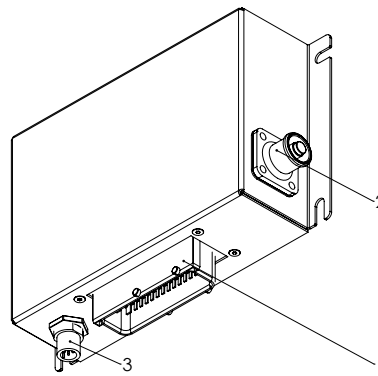

Plug view (depending on assembly)

DESCRIPTION

The CC27WP is a powerful and robust 32-bit controller with 27 inputs and outputs and 16 freely configurable I/Os with voltage and current diagnostics. It has 7 multi-function inputs and 4 half bridges for controlling motors. Due to the free configurability and high flexibility you can use the CC27WP independent of the industry.

TECHNICAL DATA

Housing	Waterproof potted V4A
Connector	1: CON 1-967280-1 JPT 42pol 2: Amphenol-Connector (Supply) 3: optionally: NMEA2000
Weight	1226 g
Temperature range acc. to ISO 16750-4	-40°C...+85°C
Environmental protection acc to ISO 20653	IP6K8 when using the covers in the connector kit and the cable harness sheath acc. to the accessories list CAUTION! Follow the mechanical instructions!
Current consumption	40 mA at 24 V; 60 mA at 12 V
Fuse protection	Depending on load
Total inputs and outputs	28/29: 16 I/Os, 7 Multifunctional inputs, 4 Motor Halfbridges 1 Reference voltage output 1 Analog input (optionally)
Inputs	16 I/Os: 0...32 V Configurable and depending on assembly: 7 Multifunctional inputs: Analog inputs 0...16.9 V, switchable to 0...32 V, Current input (330 Ω), 1 kΩ Pull-Up (vs. V _{ref} or V _s) or Frequency input
Outputs	I/Os: Digital, positive switching PWM-output Configurable: 4 Motor Halfbridges or 2 Motor Fullbridges Reference voltage: 5 V or 10 V
Supply voltage	9...32 V (Code B at 12 V, Code E at 24 V, acc. to ISO 16750-2) 11.6...32 V for 10 V Reference voltage output
Overvoltage protection	≥ 33 V

TECHNICAL DATA (CONTINUED)

Quiescent current	600 µA at 24 V; 300 µA at 12 V
Reverse polarity protection	yes
CAN interfaces	ISO 11898-2:2016 capable CAN-Bus Transceiver, CAN-FD capable
Other interfaces	LIN, RS232, RS485 - depending on variant

REGULATORY APPROVALS AND TESTING

E1 approval	10 R - 06 9866
Electrical tests	Acc. to ISO 16750-2 or -4: Short circuit Reverse polarity Disconnection pin and connector Long-term overvoltage at T _{max} -20 °C Storage test at T _{max} and T _{min} Operation test at T _{max} and T _{min} Startpuls (form. Pulse 4 acc. to ISO 7637) Superimposed alternating voltage Slow decrease and increase of supply voltage Momentary drop in supply voltage Reset behaviour at voltage drop Acc. to ISO 7637-2: Pulse 1, 2a, 2b, 3a, 3b Acc. to ISO 10605: ESD-safe up to 15 kV

SOFTWARE/PROGRAMMING

Programming System	MRS APPLICS STUDIO The Applics Studio is the new development and tool platform for our assemblies. Program your MRS controls quickly and easily with our stand-alone software. The focus is on your application.
--------------------	--

INPUT FEATURES - SUMMARY

Pin 20, 21, 22, 24, 25, 26, 27 (Multi-functional inputs)	Programmable as Analog- or Digital input, Frequency input, Current input or Sensor input		Resolution	12 Bit
Voltage input 0...16.9 V (see A) ¹	Input resistance	36 kΩ	Input frequency	$f_g^2 = 115 \text{ Hz}$
	Deviation	$\leq 3 \%$		
Voltage input 0...32 V (see B)	Input resistance	30 kΩ	Input frequency	$f_g^2 = 220 \text{ Hz}$
	Deviation	$\leq 3 \%$		
Digital input ³	Input resistance	36 kΩ	Switch-on threshold	6.1 V $\pm 0.3 \text{ V}$
	Switch-off threshold	4.1 V $\pm 0.3 \text{ V}$		
Frequency input (see C) ³	Input resistance	36 kΩ	Switch-on threshold	3.1 V $\pm 0.3 \text{ V}$
	Switch-off threshold	2.4 V $\pm 0.3 \text{ V}$ (up to 8 kHz)	Switch-off threshold	4.1 V $\pm 0.3 \text{ V}$
	Min. pulse width	5 μs		
	Meas. range PWM	13...99 %		
	Deviation Frequency measurement	$\leq 3 \%$		
Current input 0...27.5 mA (see D)	Input resistance	330 Ω to GND	Conversion factor	1 mA ≈ 77.4 digits
	Deviation	$\leq 3 \%$		
Sensor input (see E)	Input resistance	1 kΩ to Supply/Vref (Depending on assembly, see S.10)		
Pin 2, 3, 4, 5, 6, 7, 8, 9, 10, 11, 12, 13 (I/Os with BTS)	Programmable as Analog- or Digital input		Resolution	12 Bit
Voltage input 0...32 V (across multiplexer, see E)	Input resistance	65 kΩ ⁴	Input frequency	$f_g^2 = 190 \text{ Hz}$
	Deviation	$\leq 3 \%$		
Digital input	Input resistance	65 kΩ	Switch-on threshold	6.1 V $\pm 0.3 \text{ V}$
	Switch-off threshold	4.1 V $\pm 0.3 \text{ V}$		
Pin 38, 39, 40, 41 (I/Os with VNQ)	Programmable as Analog- or Digital input		Resolution	12 Bit
Voltage input 0...32 V (see E)	Input resistance	25 kΩ ⁴	Input frequency	$f_g^2 = 190 \text{ Hz}$
	Deviation	$\leq 3 \%$		
Digital input	Input resistance	25 kΩ	Switch-on threshold	6.1 V $\pm 0.3 \text{ V}$
	Switch-off threshold	4.1 V $\pm 0.3 \text{ V}$		
Pin 19	Programmable as Analog- or Digital input		Resolution	12 Bit
Voltage input 0...32 V	Input resistance	40 kΩ	Input frequency	$f_g^2 = 213 \text{ Hz}$
	Deviation	$\leq 3 \%$		
Digital input	Input resistance	40 kΩ	Switch-on threshold	6.1 V $\pm 0.3 \text{ V}$
	Switch-off threshold	4.1 V $\pm 0.3 \text{ V}$		

¹Standard configuration²Cut-off frequency (-3 dB), measured with square signal 0...10 V_{Peak} ³When using the standard configuration, see¹⁴Depending on the input voltage (I/O); $\leq 1 \text{ V}$ supply voltage

HIGHSIDE OUTPUTS FEATURES

Pin 38, 39, 40, 41 (VNQ)	Protective circuit for inductive loads	Integrated	Pin 2, 3, 4, 5, 6, 7, 8, 9, 10, 11, 12, 13 (BTS)	Protective circuit for inductive loads	Integrated
	Diagnosis of wire breakage	Via current sense		Diagnosis of wire breakage	Via current sense
	Diagnosis short circuit	Via current sense		Diagnosis short circuit	Via current sense
Digital, positive switching (High-Side; see E) inclusive INA-Current sense	Switching voltage Switching current Deviation current sense INA293	9-32 V DC see load tests >500 mA <3 %	Digital, positive switching (High-Side; see E)	Switching voltage Switching current Current sense	9-32 V DC see load tests see Datasheet Infineon BTS 6143 D
PWM output (see E)	Output frequency Resolution Switching current	10 Hz...1 kHz 1 ‰ see load tests	PWM output (see E)	Output frequency Resolution Switching current	10 Hz...1 kHz 1 ‰ see load tests
Short circuit protection against GND and U_B	Internal overtemperature protection, latch-off can be realized by software application		Short circuit protection against GND and U_B	Switching-off is controlled by high side driver for each output channel (latch-off)	
Overload protection	Internal overtemperature protection, latch-off can be realized by software application		Overload protection	Internal overtemperature protection, latch-off can be realized by software application	

MOTOR OUTPUTS FEATURES

Pin 33, 34, 35, 36 (Motor outputs)	Protective circuit for inductive loads	Integrated
	Diagnosis of wire breakage	Via current sense
	Diagnosis short circuit	Via current sense
Motor output (2 full bridges or 4 half bridges)	Switching voltage max. Switching current Frequency	9-32 V see Load tests 0...20 kHz
	Current sense	see Datasheet Infineon BTN 8962TA
Short circuit protection against GND and U _B	Short-term current limitation up to over-temperature cut-off (latch-off)	
Overload protection	Overtemperature shut down integrated	

OVERVIEW OF THE TIMER CHANNELS

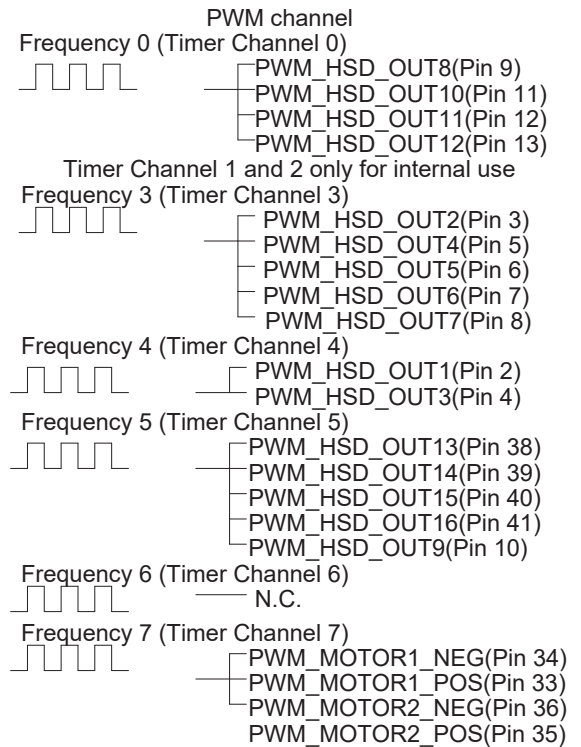

Duty Cycle selectable different per output

LOAD TESTS AT T_{+85 °C} HSD OUTPUTS

Test without PWM	Load	Duration	Test with PWM	PWM / DC	Load	Duration
at 14 V V _S	12 x BTS (2, 3, 4, 5, 6, 7, 8, 9, 10, 11, 12, 13) each 7.5 A 4 x VNQ (38, 39, 40, 41) each 1.7 A	Permanent	at 14 V V _S	500 Hz 90 %	12 x BTS (2, 3, 4, 5, 6, 7, 8, 9, 10, 11, 12, 13) each 3.9 A 4 x VNQ (38, 39, 40, 41) each 1.5 A	Permanent

measured at +85°C, 14 V supply voltage, resistive load

LOAD TESTS AT T_{+85 °C} HSD AND MOTOR OUTPUTS

Test without PWM	Load	Duration
at 14 V V _S	12 x BTS (2, 3, 4, 5, 6, 7, 8, 9, 10, 11, 12, 13) each 7.4 A 4 x VNQ (38, 39, 40, 41) each 1.93 A 4 x Motor outputs (33, 34, 35, 36) each 3.67 A	Permanent

measured at +85°C, 14 V supply voltage, resistive load

PIN ASSIGNMENT POWER SUPPLY AND INTERFACES 42 PIN CONNECTOR (CONNECTOR 1)

Pin	Pin Description	Pin	Pin Description
1	GND / contact 31	28	Supply voltage / contact 30
14	N.C.	29	GND / contact 31
15	GND / contact 31	30	Supply voltage CPU / contact 30
16	ignition / contact 15	31	CAN0-H
17	CAN0-L	32	Sensor supply max. 500 mA, 5V / 10 V V_{ref}
18	LIN, RS485A, RS232TX depending on assembly	37	CAN1-L
19	Analog input, RS485B, RS232RX dep. on assembly	42	Supply voltage / contact 30
23	CAN1-H		

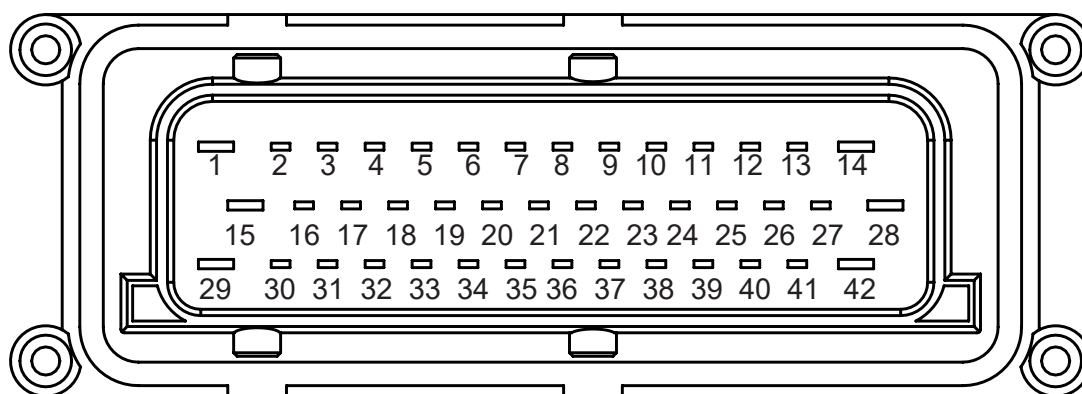

Pin assignment connector 42 Pin (1)

PIN ASSIGNMENT POWER SUPPLY

AMPHENOL SURLOCK SLPRBBPSO CONNECTOR (CONNECTOR 2)

Pin	Pin Description
1	Supply voltage / contact 30



Amphenol connector (2)

PIN ASSIGNMENT POWER SUPPLY AND INTERFACES NMEA CONNECTOR (CONNECTOR 3, OPTIONALLY)

Pin	Pin Description
1	Shield
2	Supply voltage CPU / contact 30
3	GND / contact 31
4	CAN2-H
5	CAN2-L

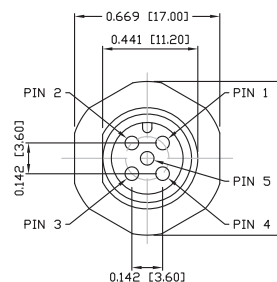

Pin assignment NMEA-Connector (3)

PIN ASSIGNMENT IN- AND OUTPUTS 42 PIN CONNECTOR (CONNECTOR 1, DEPENDING ON ASSEMBLY)

Pin	Programm Signal	Pin Description	Pin	Programm Signal	Pin Description
2	AIM_IO1 DIM_IO1 DO_HSD_OUT1 AI_HSD_SENSE1 PWM_HSD_OUT1	Analog input 1 or Digital input 1 or Digital output 1 with Current sense and PWM output ⁵	13	AIM_IO12 DIM_IO12 DO_HSD_OUT12 AI_HSD_SENSE12 PWM_HSD_OUT12	Analog input 12 or Digital input 12 or Digital output 12 with Current sense and PWM output ⁵
3	AIM_IO2 DIM_IO2 DO_HSD_OUT2 AI_HSD_SENSE2 PWM_HSD_OUT2	Analog input 2 or Digital input 2 or Digital output 2 with Current sense and PWM output ⁵	19	AI_IN8 DI_AI_IN8	Analog input Digital input
4	AIM_IO3 DIM_IO3 DO_HSD_OUT3 AI_HSD_SENSE3 PWM_HSD_OUT3	Analog input 3 or Digital input 3 or Digital output 3 with Current sense and PWM output ⁵	20	AIM_IN1 DIM_IN1 MC_FREQ_IN1 DOM_RS1_30V DOM_PD1 DOM_PU1	Analog input 1 or Digital input 1 or Frequency input 1 Input configurable: Range selection 0-32V 330 Ω Pull down ⁶ 1 kΩ Pull up to VDD
5	AIM_IO4 DIM_IO4 DO_HSD_OUT4 AI_HSD_SENSE4 PWM_HSD_OUT4	Analog input 4 or Digital input 4 or Digital output 4 with Current sense and PWM output ⁵	21	AIM_IN2 DIM_IN2 MC_FREQ_IN2 DOM_RS2_30V DOM_PD2 DOM_PU2	Analog input 2 or Digital input 2 or Frequency input 2 Input configurable: Range selection 0-32V 330 Ω Pull down ⁶ 1 kΩ Pull up to VDD
6	AIM_IO5 DIM_IO5 DO_HSD_OUT5 AI_HSD_SENSE5 PWM_HSD_OUT5	Analog input 5 or Digital input 5 or Digital output 5 with Current sense and PWM output ⁵	22	AIM_IN3 DIM_IN3 MC_FREQ_IN3 DOM_RS3_30V DOM_PD3 DOM_PU3	Analog input 3 or Digital input 3 or Frequency input 3 Input configurable: Range selection 0-32V 330 Ω Pull down ⁶ 1 kΩ Pull up vs. VDD
7	AIM_IO6 DIM_IO6 DO_HSD_OUT6 AI_HSD_SENSE6 PWM_HSD_OUT6	Analog input 6 or Digital input 6 or Digital output 6 with Current sense and PWM output ⁵	24	AIM_IN4 DIM_IN4 MC_FREQ_IN4 DOM_RS4_30V DOM_PD4 DOM_PU4	Analog input 4 or Digital input 4 or Frequency input 4 Input configurable: Range selection 0-32V 330 Ω Pull down ⁶ 1 kΩ Pull up to VDD/V _{ref}
8	AIM_IO7 DIM_IO7 DO_HSD_OUT7 AI_HSD_SENSE7 PWM_HSD_OUT7	Analog input 7 or Digital input 7 or Digital output 7 with Current sense and PWM output ⁵	25	AIM_IN5 DIM_IN5 MC_FREQ_IN5 DOM_RS5_30V DOM_PD5 DOM_PU5	Analog input 5 or Digital input 5 or Frequency input 5 Input configurable: Range selection 0-32V 330 Ω Pull down ⁶ 1 kΩ Pull up to VDD/V _{ref}
9	AIM_IO8 DIM_IO8 DO_HSD_OUT8 AI_HSD_SENSE8 PWM_HSD_OUT8	Analog input 8 or Digital input 8 or Digital output 8 with Current sense and PWM output ⁵	26	AIM_IN6 DIM_IN6 MC_FREQ_IN6 DOM_RS6_30V DOM_PD6 DOM_PU6	Analog input 6 or Digital input 6 or Frequency input 6 Input configurable: Range selection 0-32V 330 Ω Pull down ⁶ 1 kΩ Pull up to VDD/V _{ref}
10	AIM_IO9 DIM_IO9 DO_HSD_OUT9 AI_HSD_SENSE9 PWM_HSD_OUT9	Analog input 9 or Digital input 9 or Digital output 9 with Current sense and PWM output ⁵	27	AIM_IN7 DIM_IN7 MC_FREQ_IN7 DOM_RS7_30V DOM_PD7 DOM_PU7	Analog input 7 or Digital input 7 or Frequency input 7 Input configurable: Range selection 0-32V 330 Ω Pull down ⁶ 1 kΩ Pull up to VDD/V _{ref}
11	AIM_IO10 DIM_IO10 DO_HSD_OUT10 AI_HSD_SENSE10 PWM_HSD_OUT10	Analog input 10 or Digital input 10 or Digital output 10 with Current sense and PWM output ⁵			
12	AIM_IO11 DIM_IO11 DO_HSD_OUT11 AI_HSD_SENSE11 PWM_HSD_OUT11	Analog input 11 or Digital input 11 or Digital output 11 with Current sense and PWM output ⁵			

PIN ASSIGNMENT IN- AND OUTPUTS 42 PIN CONNECTOR (CONNECTOR 1)

Pin	Programm Signal	Pin Description	Pin	Programm Signal	Pin Description
32	AI_VREF DO_VREF_EN DO_RS_DCDC_10V	Analog input or activation V_{ref} with voltage selection 10V/5V	38	AIM_IO13 DIM_IO13 DO_PWM_HSD_OUT13 PWM_HSD_OUT13 AI_INA_OUT13	Analog input 13 or Digital input 13 or Digital output with PWM output and with INA current sense
33	PWM_MOTOR1_POS AI_MOTOR1_SENSE_POS AI_MOTOR1_POS DO_MOTOR1_POS	Motor fullbridge 1 pos setting PWM Motor 1 positive sense of rotation ⁵ with current sense and Voltage monitoring / short circuit detection Digital output	39	AIM_IO14 DIM_IO14 DO_PWM_HSD_OUT14 PWM_HSD_OUT14 AI_INA_OUT14	Analog input 14 or Digital input 14 or Digital output with PWM output and with INA current sense
34	PWM_MOTOR1_NEG AI_MOTOR1_SENSE_NEG AI_MOTOR1_NEG DO_MOTOR1_NEG	Motor fullbridge 1 neg setting PWM Motor 1 negative sense of rotation ⁵ with current sense and Voltage monitoring / short circuit detection Digital output	40	AIM_IO15 DIM_IO15 DO_PWM_HSD_OUT15 PWM_HSD_OUT15 AI_INA_OUT15	Analog input 15 or Digital input 15 or Digital output with PWM output and with INA current sense
35	PWM_MOTOR2_POS AI_MOTOR2_SENSE_POS AI_MOTOR2_POS DO_MOTOR2_POS	Motor fullbridge 2 pos setting PWM Motor 1 positive sense of rotation ⁵ with current sense and Voltage monitoring / short circuit detection Digital output	41	AIM_IO16 DIM_IO16 DO_PWM_HSD_OUT16 PWM_HSD_OUT16 AI_INA_OUT16	Analog input 16 or Digital input 16 or Digital output with PWM output and with INA Current sense
36	PWM_MOTOR2_NEG AI_MOTOR2_SENSE_NEG AI_MOTOR2_NEG DO_MOTOR2_NEG	Motor fullbridge 2 neg setting PWM Motor 1 negative sense of rotation ⁵ with current sense and Voltage monitoring / short circuit detection Digital output			

⁵ initialised with $f = 1$ kHz and 0% DC, DC adjustable in 1‰ steps (1000=100%)

⁶ when using the pull down resistance, no higher voltage than 9 V may be applied

PIN FEATURE MAP

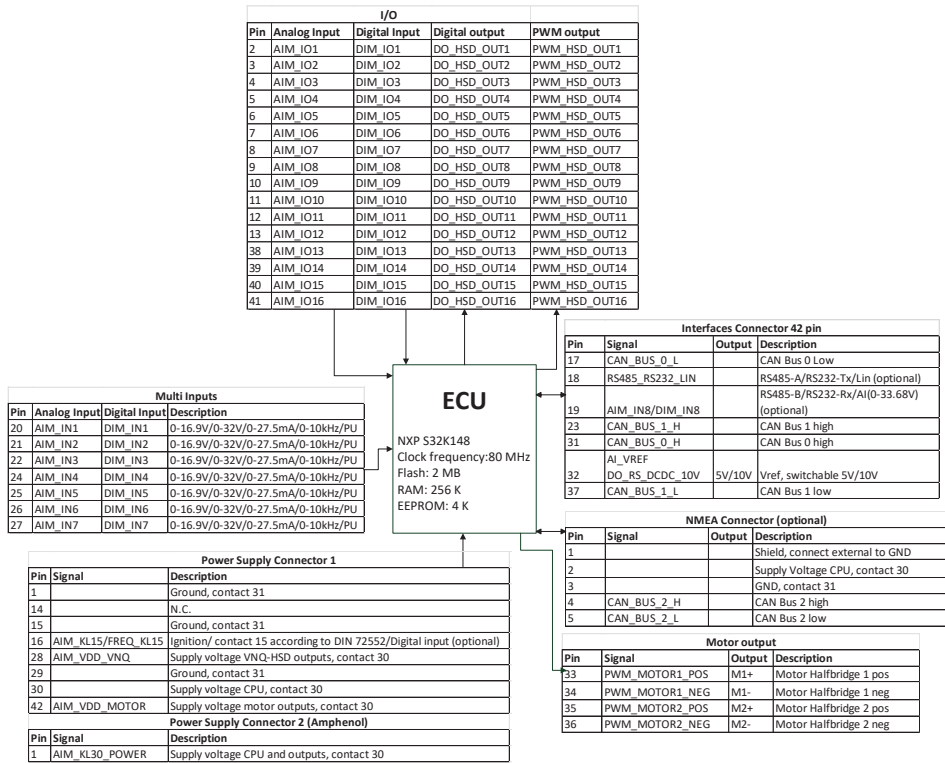

BLOCK FUNCTION DIAGRAM

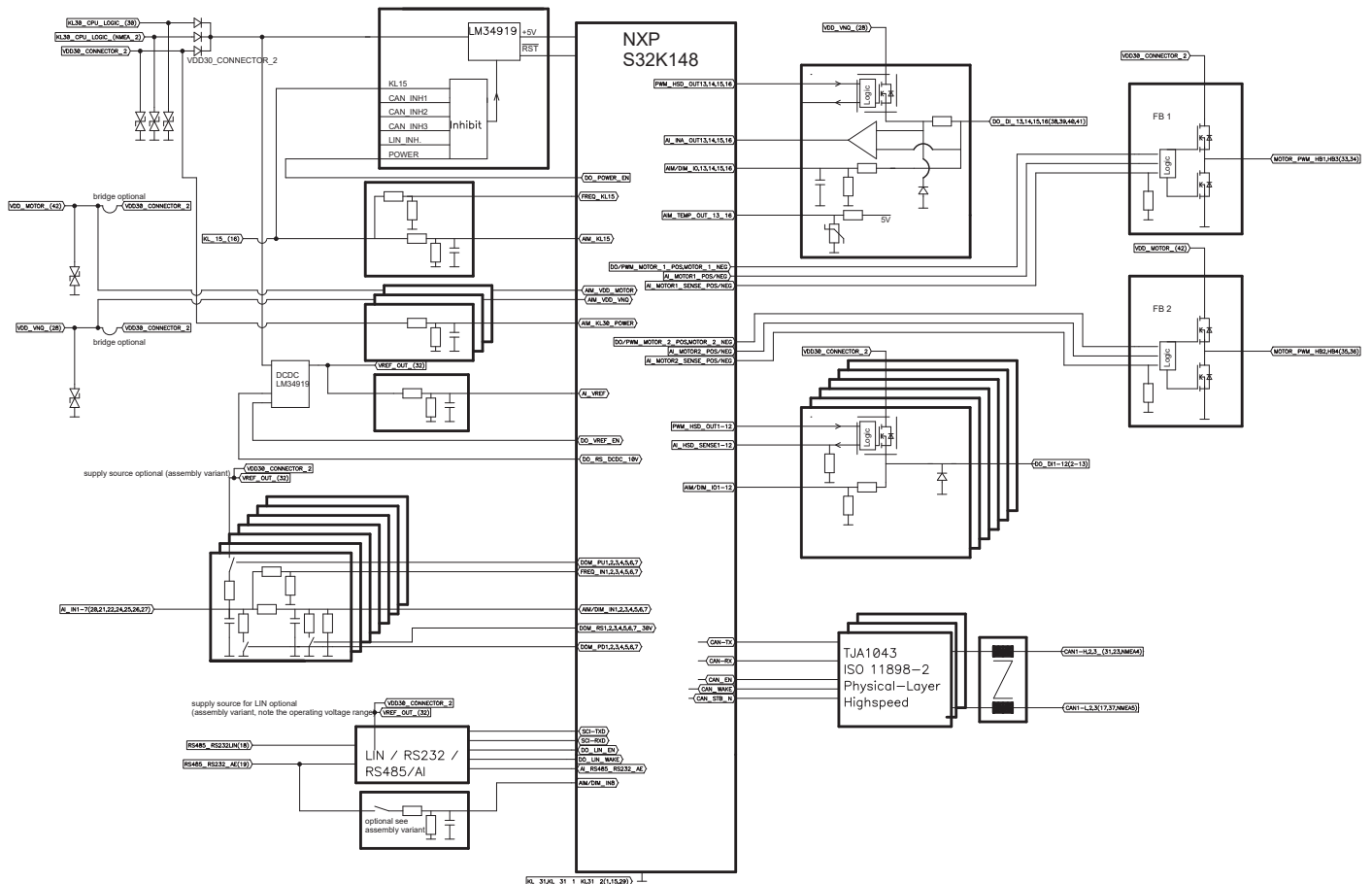

TECHNICAL DRAWING IN MM [INCH], TOLERANCES ACCORDING TO ISO 2768-1 V

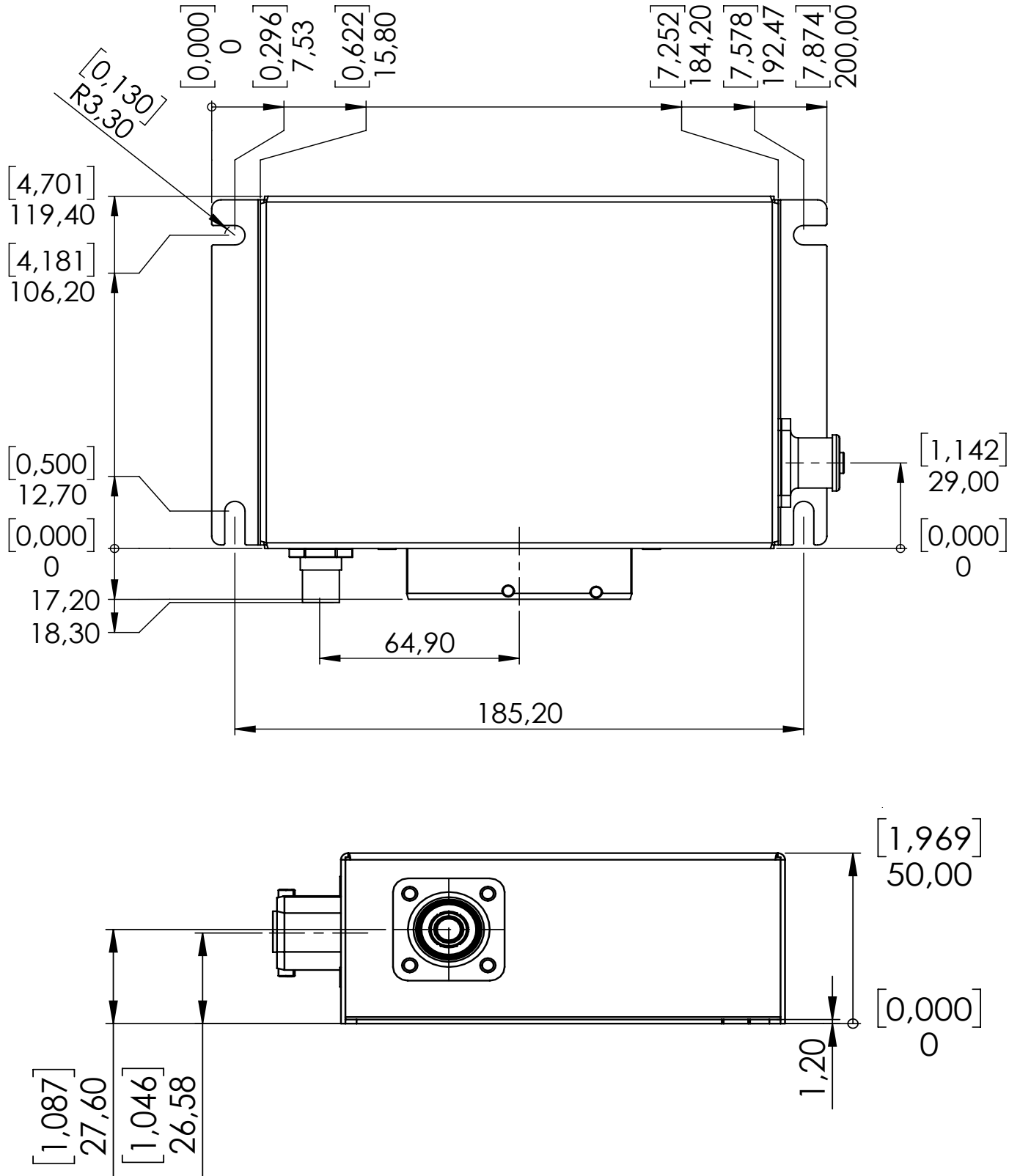

ASSEMBLY VARIANTS AND ORDERING INFORMATIONS

	Pin numbering of the inputs						I/Os	Interfaces		Wake Up	Remarks
	A Voltage 0...16.9 V	B Voltage 0...32 V	C Frequen- cy Hz	D Current 0...27.5 mA	E 1 kΩ pull-up	F optional as analog input, digital output or PWM output		CAN Bus High- Speed	others		
1.169.300.0200	20, 21, 22, 24, 25, 26, 27	2, 3, 4, 5, 6, 7, 8, 9, 10, 11, 12, 13, 20, 21, 22, 24, 25, 26, 27, 38, 39, 40, 41	20, 21, 22, 24, 25, 26, 27	20, 21, 22, 24, 25, 26, 27	20, 21, 22, 24 to contact 30, 25, 26, 27 to Vref	2, 3, 4, 5, 6, 7, 8, 9, 10, 11, 12, 13, 38, 39, 40, 41	CAN 0 CAN 1	LIN Master	CAN 0, CAN 1, LIN, contact 15, DO_PO- WER	Connector: JPT 42-pin, Amphenol, LIN Supply = contact 30	
1.169.300.1200	20, 21, 22, 24, 25, 26, 27	2, 3, 4, 5, 6, 7, 8, 9, 10, 11, 12, 13, 20, 21, 22, 24, 25, 26, 27, 38, 39, 40, 41	20, 21, 22, 24, 25, 26, 27	20, 21, 22, 24, 25, 26, 27	20, 21, 22, 24 to contact 30, 25, 26, 27 to Vref	2, 3, 4, 5, 6, 7, 8, 9, 10, 11, 12, 13, 38, 39, 40, 41	CAN 0 CAN 1	LIN Slave	CAN 0, CAN 1, LIN, contact 15, DO_PO- WER	Connector: JPT 42-pin, Amphenol, LIN Supply = contact 30	
1.169.300.2200	20, 21, 22, 24, 25, 26, 27	2, 3, 4, 5, 6, 7, 8, 9, 10, 11, 12, 13, 20, 21, 22, 24, 25, 26, 27, 38, 39, 40, 41	20, 21, 22, 24, 25, 26, 27	20, 21, 22, 24, 25, 26, 27	20, 21, 22, 24 to contact 30, 25, 26, 27 to Vref	2, 3, 4, 5, 6, 7, 8, 9, 10, 11, 12, 13, 38, 39, 40, 41	CAN 0 CAN 1	LIN Master	CAN 0, CAN 1, LIN, contact 15, DO_PO- WER	Connector: JPT 42-pin, Amphenol, LIN Supply = Vref	
1.169.300.4200	20, 21, 22, 24, 25, 26, 27	2, 3, 4, 5, 6, 7, 8, 9, 10, 11, 12, 13, 20, 21, 22, 24, 25, 26, 27, 38, 39, 40, 41	20, 21, 22, 24, 25, 26, 27	20, 21, 22, 24, 25, 26, 27	20, 21, 22, 24 to contact 30, 25, 26, 27 to Vref	2, 3, 4, 5, 6, 7, 8, 9, 10, 11, 12, 13, 38, 39, 40, 41	CAN 0 CAN 1	RS232	CAN 0, CAN 1, cont- act 15, DO_POWER	Connector: JPT 42-pin, Amphenol	
1.169.300.5200	20, 21, 22, 24, 25, 26, 27	2, 3, 4, 5, 6, 7, 8, 9, 10, 11, 12, 13, 20, 21, 22, 24, 25, 26, 27, 38, 39, 40, 41	20, 21, 22, 24, 25, 26, 27	20, 21, 22, 24, 25, 26, 27	20, 21, 22, 24 to contact 30, 25, 26, 27 to Vref	2, 3, 4, 5, 6, 7, 8, 9, 10, 11, 12, 13, 38, 39, 40, 41	CAN 0 CAN 1	RS485	CAN 0, CAN 1, cont- act 15, DO_POWER	Connector: JPT 42-pin, Amphenol	
1.169.300.0070¹	20, 21, 22, 24, 25, 26, 27	2, 3, 4, 5, 6, 7, 8, 9, 10, 11, 12, 13, 20, 21, 22, 24, 25, 26, 27, 38, 39, 40, 41	20, 21, 22, 24, 25, 26, 27	20, 21, 22, 24, 25, 26, 27	20, 21, 22, 24, 25, 26, 27 to contact 30	2...13, 38...41 with PWM + Connector 4: 1...16 without PWM	CAN 0 CAN 1 CAN 2	LIN Master	CAN 0, CAN 1, CAN 2, LIN, contact 15, DO_POWER	Connector: JPT 42-pol., JPT 16-pin, Amphenol, NMEA, LIN Supply = contact 30	

¹ Variant with Power extension, see separate datasheet

ACCESSORIES

Description	Order number
Applis Studio Bundle without PCAN	1.100.200.01
Connector package Basis	108888
Connector package NMEA2000	302392
Connector package Power Bolt Amphenol SurLok SLPPB50BSO	302393
Programming cable set	302378
PCAN FD USB Adapter	503750
Cable harness sheath	Available from independent retailers



Image depending on assembly

MANUFACTURER

MRS Electronic GmbH & Co. KG
Klaus-Gutsch-Str. 7
78628 Rottweil
Germany

NOTES ON WIRING AND CABLE ROUTING

The electronic system and the power outputs of a control unit must be supplied by the same power supply system.

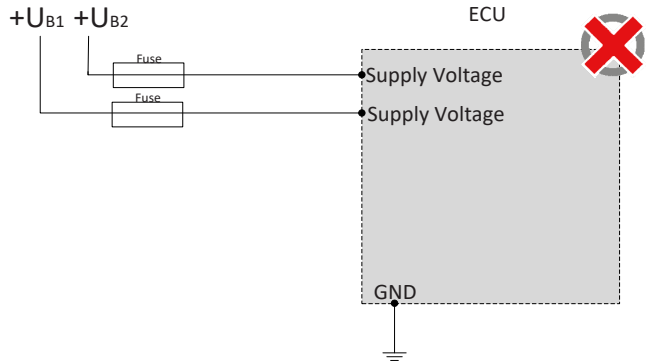
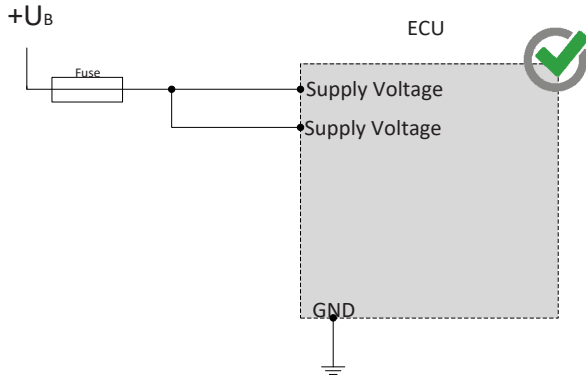

PWM outputs may not be connected with each other or bypassed.

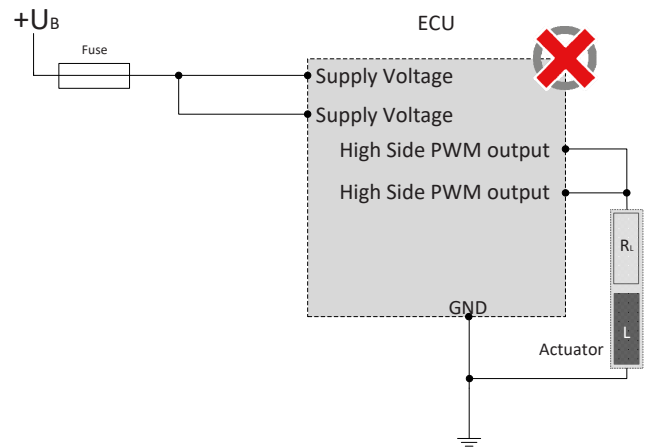
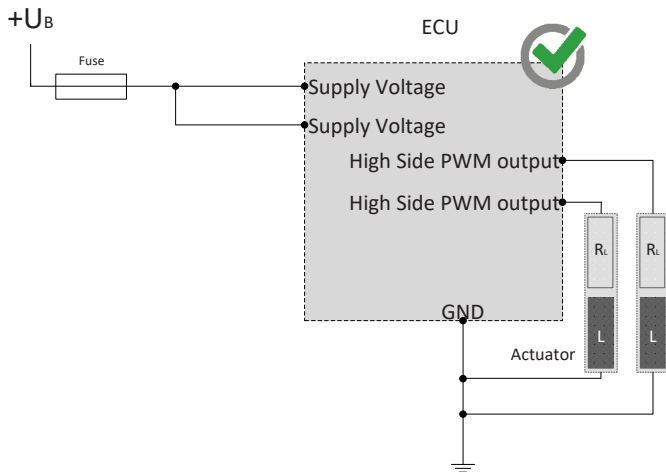

Halfbridge outputs must not be connected in parallel

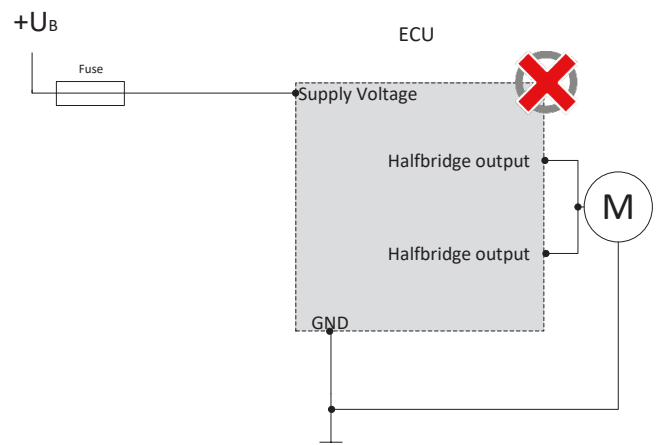
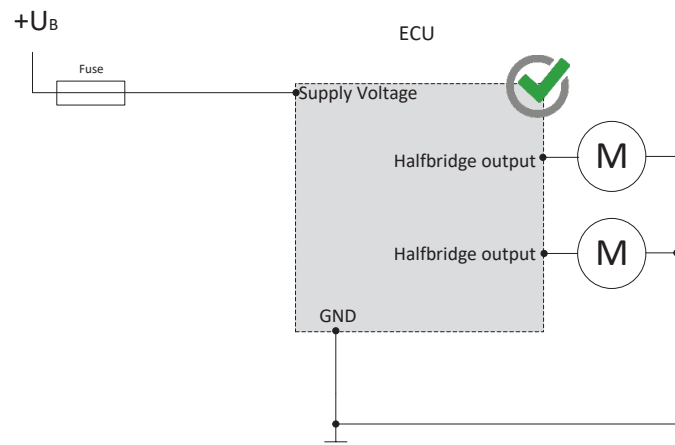

To comply with the IP protection class, the wiring harness attached to the mating connector must be routed through the cable harness sheath and the mating connector must be connected to the control unit. The cover included in the connector kit must then be closed over the mating connector. The cable harness sheath must be secured in the groove in the cover using cable ties.

NOTES ON WIRING AND CABLE ROUTING

The pins (I/Os) can be used in combination and may not be switched externally against a higher voltage level than supply voltage.

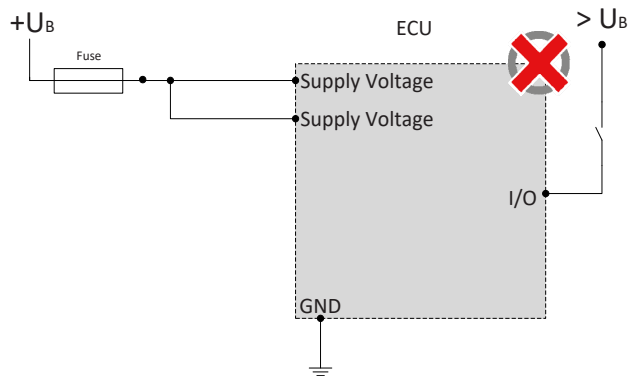
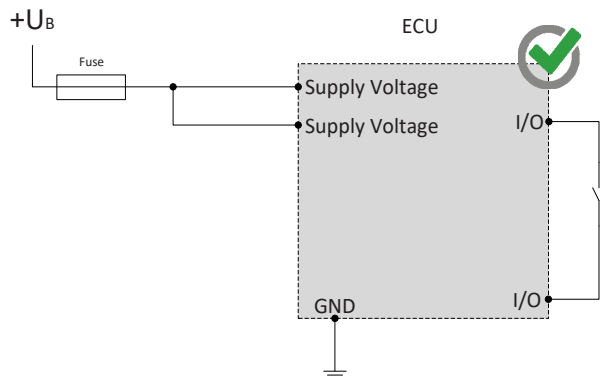

PWM- and hightside outputs may only be switched to ground.

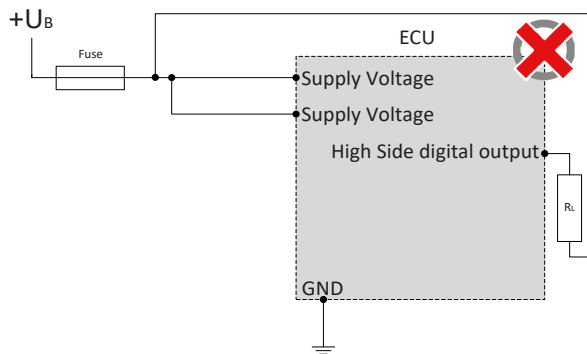
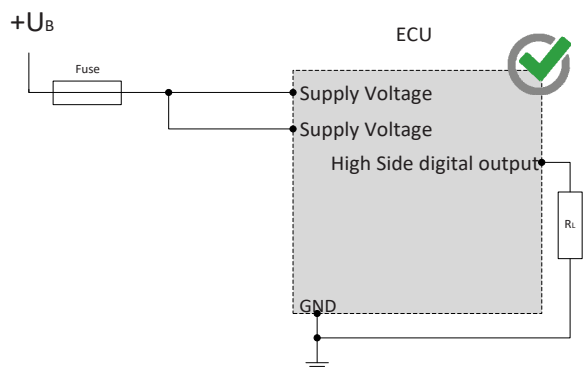
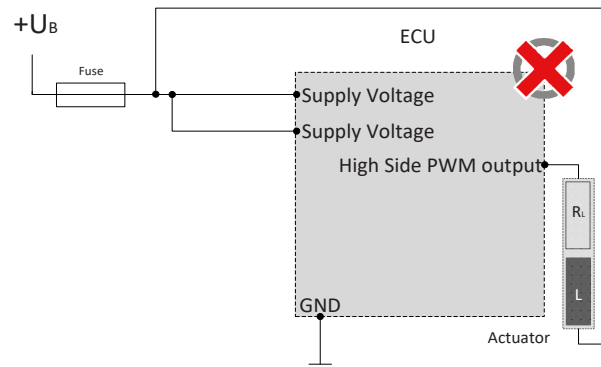
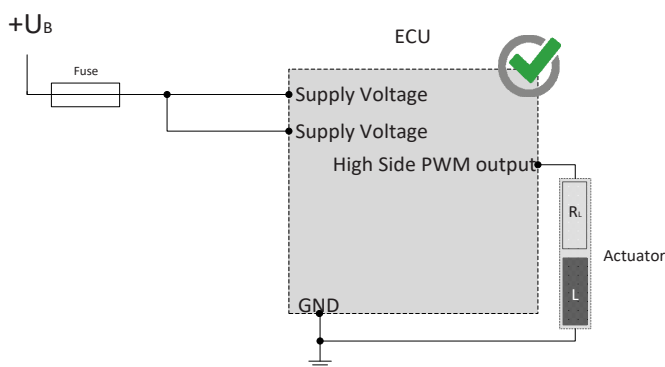

The sensor supplies can be "lifted" through an external circuitry, for example the creation of higher voltage, as they only work as a voltage source but not as voltage drain. The lift of a voltage source may lead to unforeseen malfunctions and damages of the control unit in case of permanent operation.

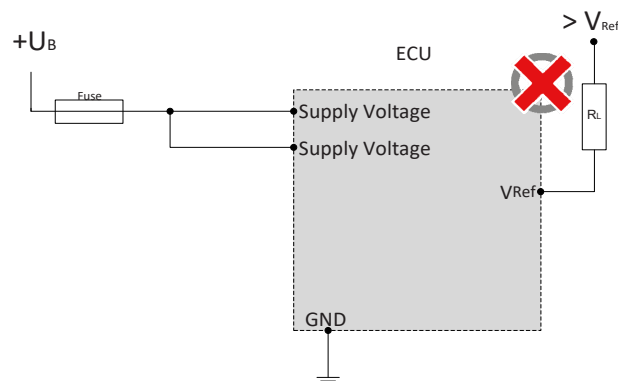
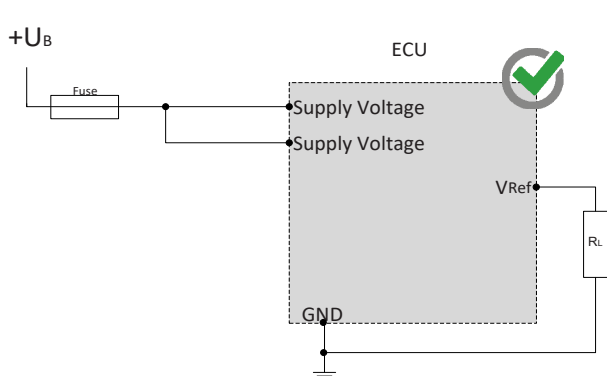

NOTES ON WIRING AND CABLE ROUTING

CAN bus communication is the main communication between the control unit and the vehicle. Therefore, connect the CAN bus with special care and check the correct communication with the vehicle to avoid undesired behavior.

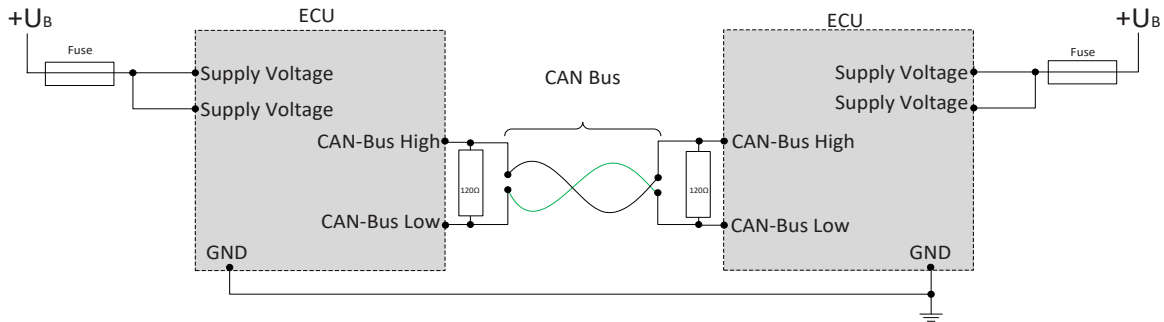

When using the input with pull-down resistance (using DOM_PD), you must not connect a greater voltage than 9 V to the input.

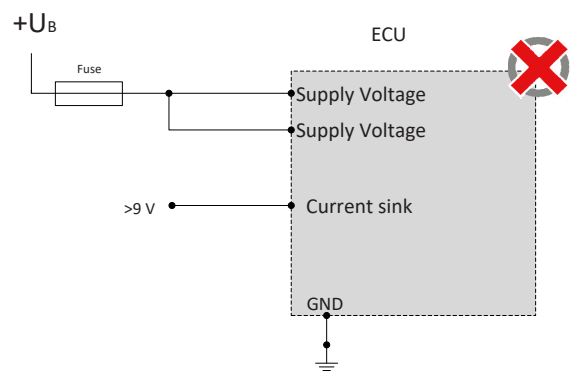
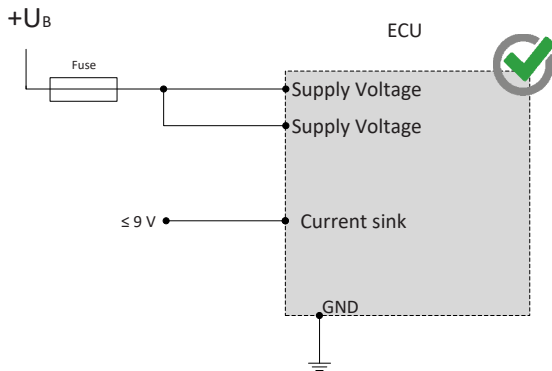

The control must be protected against overload (see performance data)

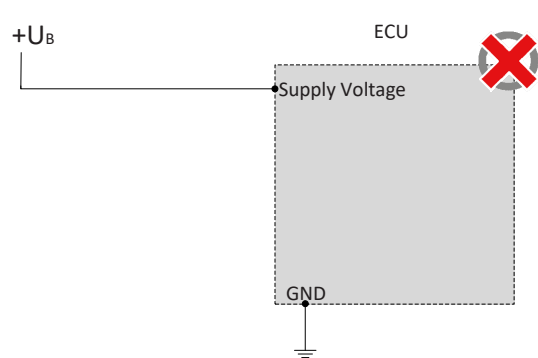
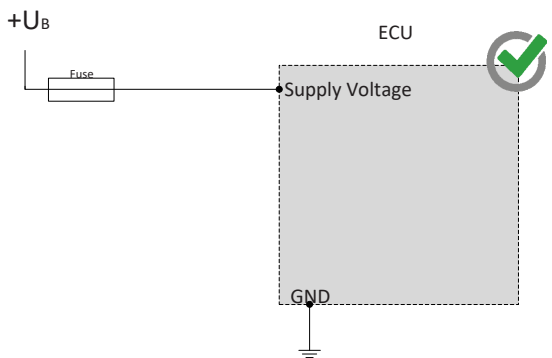

To prevent damage to the hardware, a ramp function, e.g. via the graphic programming block "Ramp", must be used. The description for this is stored in the Developers Studio.

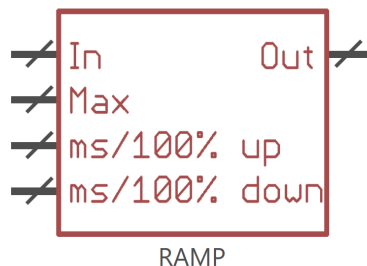

SAFETY AND INSTALLATION INFORMATION

It is essential to read the instructions in full thoroughly before working with the device.

Please note and comply with the instructions in the operating instructions and the information in the device data sheet, see www.mrs-electronic.com

Staff qualification: Only staff with the appropriate qualifications may work on this device or in its proximity.

SAFETY



WARNING! Danger as a result of a malfunction of the entire system.

Unforeseen reactions or malfunctions of the entire system may jeopardise the safety of people or the machine.

- Ensure that the device is equipped with the correct software and that the wiring and settings on the hardware are appropriate.



WARNING! Danger as a result of unprotected moving components.

Unforeseen dangers may occur from the entire system when putting the device into operation and maintaining it.

- Switch the entire system off before carrying out any work and prevent it from unintentionally switching back on.
- Before putting the device into operation, ensure that the entire system and parts of the system are safe.
- The device should never be connected or separated under load or voltage.



CAUTION! Risk of burns from the housing.

The temperature of the device housing may be elevated.

- Do not touch the housing and let all system components cool before working on the system.

PROPER USE

The device is used to control or switch one or more electrical systems or sub-systems in motor vehicles and machines and may only be used for this purpose. The device may only be used in an industrial setting.



WARNING! Danger caused by incorrect use.

The device is only intended for use in motor vehicles and machines.

- Use in safety-related system parts for personal protection is not permitted.
- Do not use the device in areas where there is a risk of explosion.

Correct use:

- operating the device within the operating areas specified and approved in the associated data sheet.
- strict compliance with these instructions and no other actions which may jeopardise the safety of individuals or the functionality of the device.

Obligations of the manufacturer of entire systems

It is necessary to ensure that only functional devices are used. If devices fail or malfunction, they must be replaced immediately.

System developments, installation and the putting into operation of electrical systems may only be carried out by trained and experienced staff who are sufficiently familiar with the handling of the components used and the entire system.

It is necessary to ensure that the wiring and programming of the device does not lead to safety-related malfunctions of the entire system in the event of a failure or a malfunction. System behaviour of this type can lead to a danger to life or high levels of material damage.

The manufacturer of the entire system is responsible for the correct connection of the entire periphery (e.g. cable cross sections, correct selection/connection of sensors/actuators).

Opening the device, making changes to the device and carrying out repairs are all prohibited. Changes or repairs made to the cabling can lead to dangerous malfunctions. Repairs may only be carried out by MRS.

Installation

The installation location must be selected so the device is exposed to as low a mechanical and thermal load as possible. The device may not be exposed to any chemical loads.

Install the device in such a manner that the plugs point downwards. This means condensation can flow off the device. Single seals on the cables/leads must be used to ensure that no water gets into the device.

Putting into operation

The device may only be put into operation by qualified staff. This may only occur when the status of the entire system corresponds to the applicable guidelines and regulations.

FAULT CORRECTION AND MAINTENANCE



NOTE The device is maintenance-free and may not be opened.

- If the device has damage to the housing, latches, seals or flat plugs, it must be taken out of operation.

Fault correction and cleaning work may only be carried out with the power turned off. Remove the device to correct faults and to clean it.

Check the integrity of the housing and all flat plugs, connections and pins for mechanical damage, damage caused by overheating, insulation damage and corrosion. In the event of faulty switching, check the software, switches and settings.

Do not clean the device with high pressure cleaners or steam jets. Do not use aggressive solvents or abrasive substances.