

Angled view with mounting bracket

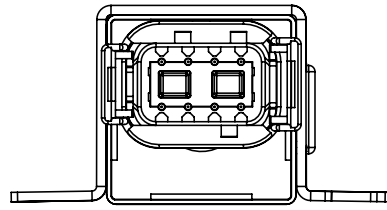

Connector view with mounting bracket

## DESCRIPTION

The Motor Controller 7.5 A CAN DTM is used for controlling DC motors. Due to the free programmability and the compact design, you can implement a wide range of applications in the smallest of spaces. In combination with the DEUTSCH DTM connector, it offers you robust quality and is ideally suited for extreme environmental conditions.

## TECHNICAL DATA

Housing	Waterproof potted plastic housing; Plastic PA66 GF30
Connector	DEUTSCH DTM04-08PA
Weight	76 g
Temperature range acc. to ISO 16750-4	-40 °C...+85 °C
Environmental protection acc. to ISO 20653	IP6K8 with correct mounting direction (plug down)
Fuse protection	1 A + Load
Total inputs and outputs	1 analog input, 1 motor output
Inputs	Analog input 0...11.4 V
Outputs	1 motor fullbridge
Supply voltage	6...32 V (Code A for 12V, Code E for 24 V, acc. to ISO 16750-2)
Overvoltage protection	≥ 33 V
Current consumption	23 mA at 12 V and 24 V
Quiescent current	700 µA at 12 V 1280 µA at 24 V
Reverse polarity protection	integrated
CAN interfaces	CAN Interface 2.0 A/B, ISO 11898-2

## REGULATORY APPROVALS AND TESTING

E1 approval 10 R - 05 7515

### Electrical tests

#### Acc. to ISO 16750-2 or -4:

Long term overvoltage at  $T_{max}$ -20 °C  
Superimposed alternating voltage  
Slow decrease and increase of supply voltage  
Momentary drop in supply voltage  
Reset behaviour at voltage drop  
Reversed voltage  
Pin disconnection  
Connector disconnection  
Short circuit  
Storage test at  $T_{min}$  and  $T_{max}$   
Operation test at  $T_{min}$  and  $T_{max}$

#### Acc. to ISO 7637-2:

Pulse 1, 2a, 2b, 3a, 3b, severity level III

#### Acc. to ISO 10605:

ESD up to ± 15 kV

Chemical tests  
(at room temperature, brushed)

#### Acc. to ISO 16750-5:2010:

Battery fluid (22 h)  
Interior cleaner (2 h)  
Glass cleaner (2 h)  
Denaturated alcohol (10 min)  
Cream, coffee whitener (22 h)

## SOFTWARE/PROGRAMMING

Programming System

### MRS APPLICS STUDIO

The Applica Studio is the new development and tool platform for our assemblies. Program your MRS controls quickly and easily with our stand-alone software. The focus is on your application.

## INPUT FEATURES - SUMMARY

<b>Pin 8 (C)</b>	Programmable as analog or digital input	
	Resolution	12 Bit
Voltage input 0...11.4 V (see <a href="#">A</a> )	Input resistance	22 kΩ
	Input frequency <sup>1</sup>	$f_g = 71 \text{ Hz}$
	Accuracy	$\leq 3 \%$
Digital input (see <a href="#">B</a> )	Input resistance	22 kΩ
	Turn-on threshold	$6.6 \pm 0.3 \text{ V}$
	Turn-off threshold	$4.9 \pm 0.3 \text{ V}$
	Accuracy	$\leq 3 \%$

<sup>1</sup> Cutoff frequency (-3 dB)

## OUTPUT FEATURES - SUMMARY

<b>Pin 2, 3 (M1, M2)</b>	Protective circuit for inductive loads	integrated
	Wire fault diagnostics	integrated
	Short circuit diagnostics	integrated
Motor-output (Full-bridge; see <a href="#">D</a> )	Switching voltage max. switching current (permanent, $T = +85 \text{ °C}$ )	6...32 V see load test
	Conversion factor	no raw value readout
	Short circuit resistance against GND and $U_s$	Shutdown of the outputs controlled by output driver

LOAD TEST AT  $T_{+85 \text{ °C}}$  MOTOR-OUTPUT (FULLBRIDGE)

Test without PWM	Test no.	Load	Duration	Test with PWM	Test no.	Freq. / duty cycle	Load	Duration
	1	7.5 A	Permanent		1	0...30 kHz 0...100 %	7.5 A	Permanent

PIN ASSIGNMENT POWER SUPPLY AND INTERFACES

Pin	Description	Pin	Description
1	KL31 / GND	6	CAN-L
4	KL30 / Supply voltage	7	CAN-H
5	KL15 / Ignition		

PIN ASSIGNMENT INPUTS AND OUTPUTS

Pin	Signal	Description	Pin	Signal	Description
2	PWM_H2	PWM 1 (M1)	8	AI_C	Analog input C or
3	PWM_H1	PWM 2 (M2)		DI_C	Digital input C

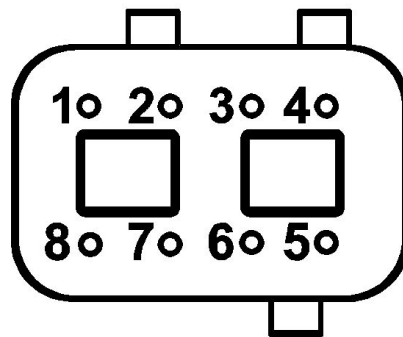

Pin assignment - bottom view

PIN - OVERVIEW

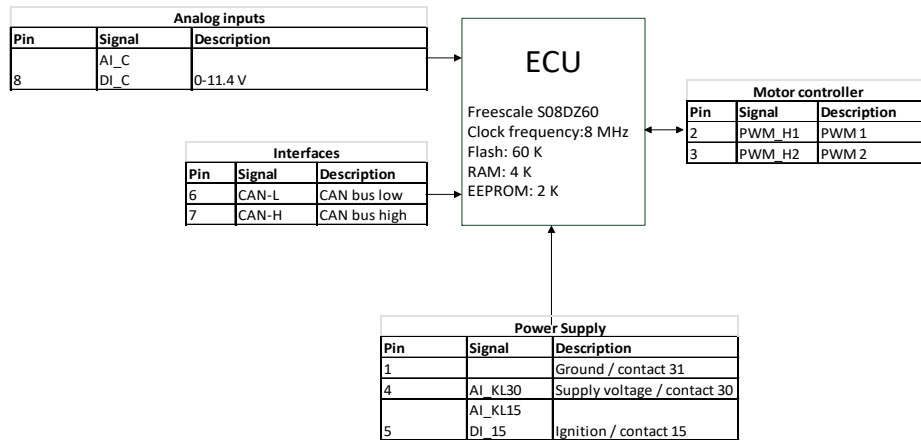

BLOCK FUNCTION DIAGRAM

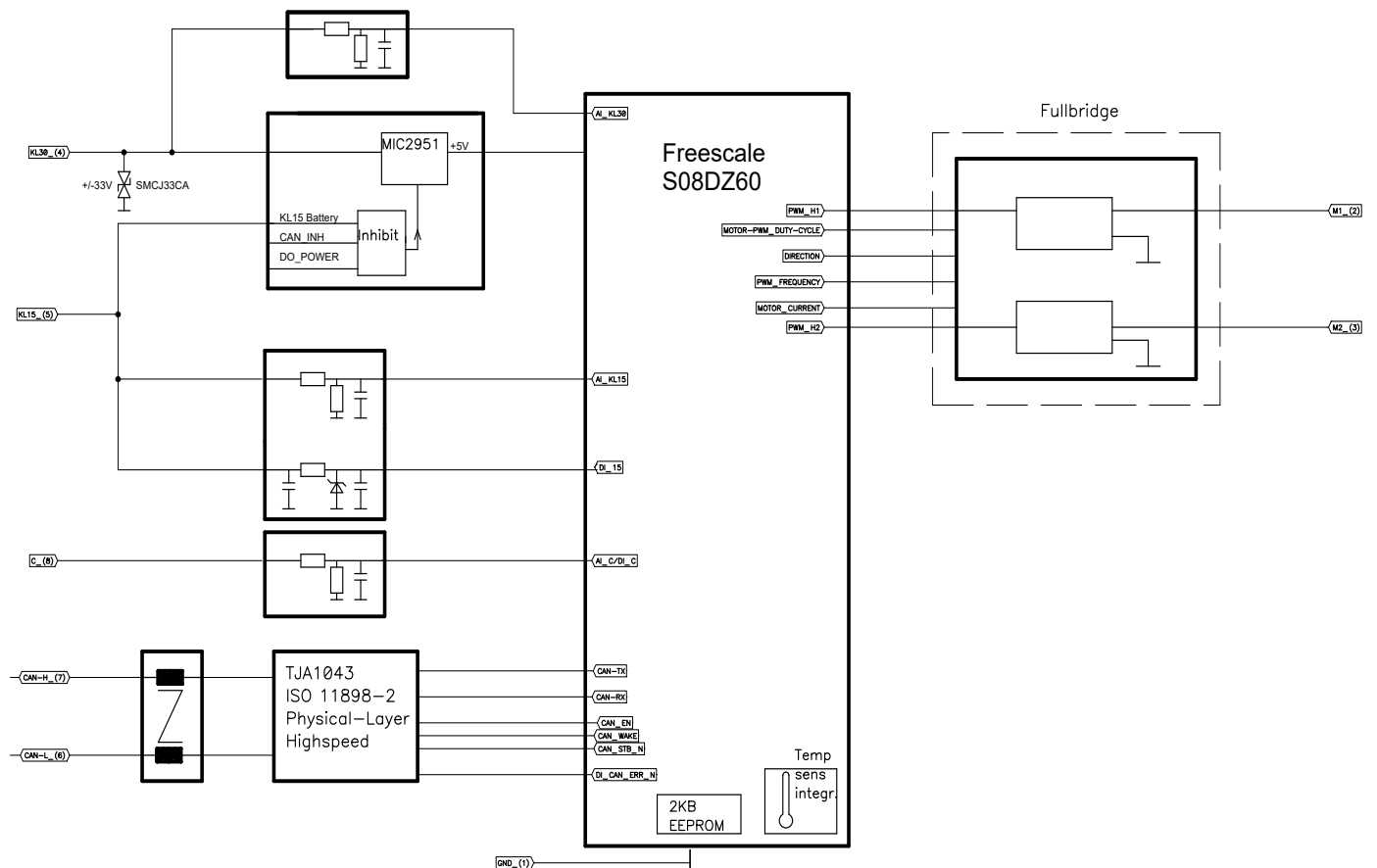

TECHNICAL DRAWING WITH MOUNTING BRACKET IN MM [INCH] , TOLERANCES ACCORDING TO ISO 2768-1 V

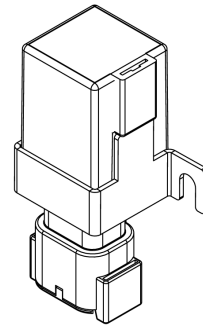
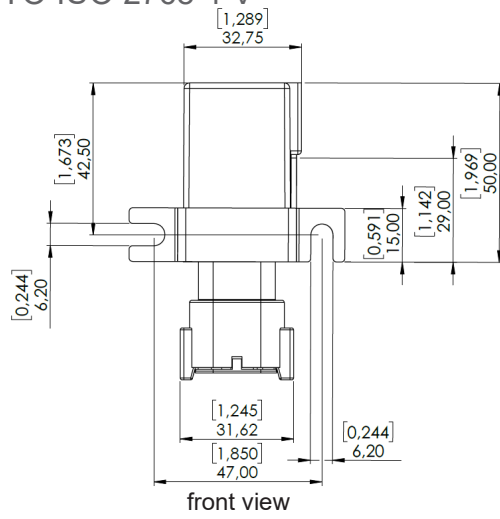

angled view

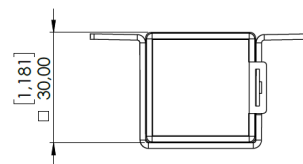
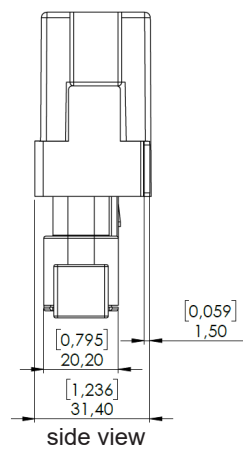

ASSEMBLY VARIANTS AND ORDERING INFORMATIONS

	Inputs numbering		Outputs numbering	Wake up sources	CAN	Remarks
	A Voltage 0...11.4 V	B Digital input	D Motor output		CAN HS	
<b>1.117.900.0000</b>	8	8	2, 3	CAN, KL15, DO_POWER	X	

SCIP number: 15fce980-1d07-4f16-9fc5-5bc3dd1a42c6

## ACCESSORIES

Description	Order number
Programming tool MRS Applies Studio	1.100.200.01
Socket package DTM04-08	301995
PCAN-USB Interface	105358
Housing bracket	1.017.080.00
Cable set to program DTM modules	302379



## MANUFACTURER

MRS Electronic GmbH & Co. KG  
Klaus-Gutsch-Str. 7  
78628 Rottweil  
Germany

NOTES ON WIRING AND CABLE ROUTING

The controller must be appropriately protected against overload (see performance data)

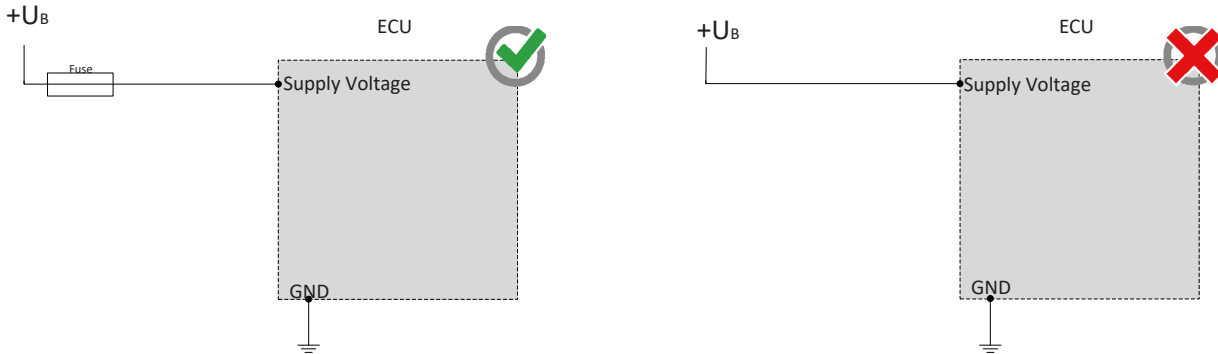

The full bridge motor outputs may only be interconnected against each other.

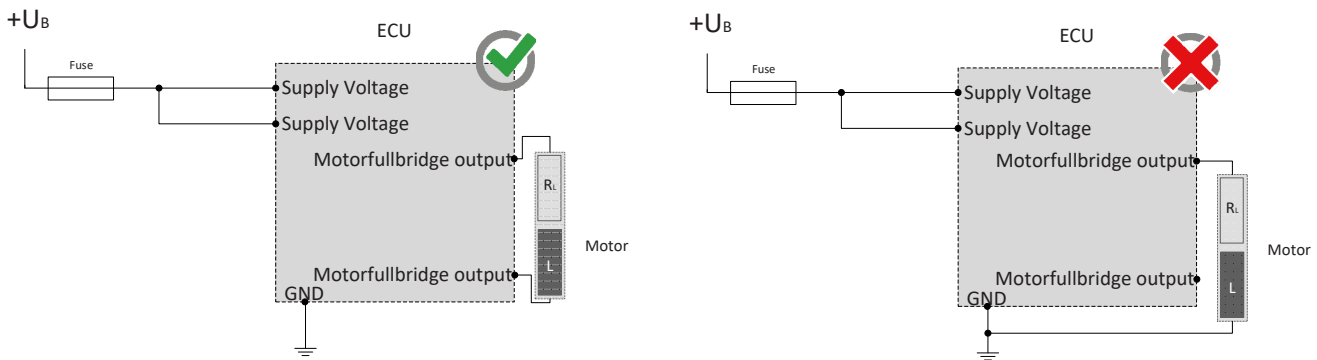

To prevent damage to the hardware, a ramp function, e.g. via the graphic programming block "Ramp", must be used. The description for this is stored in the Developers Studio.

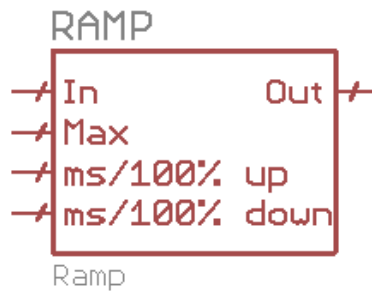

CAN bus communication is the main communication between the control unit and the vehicle. Therefore, connect the CAN bus with special care and check the correct communication with the vehicle to avoid undesired behavior.

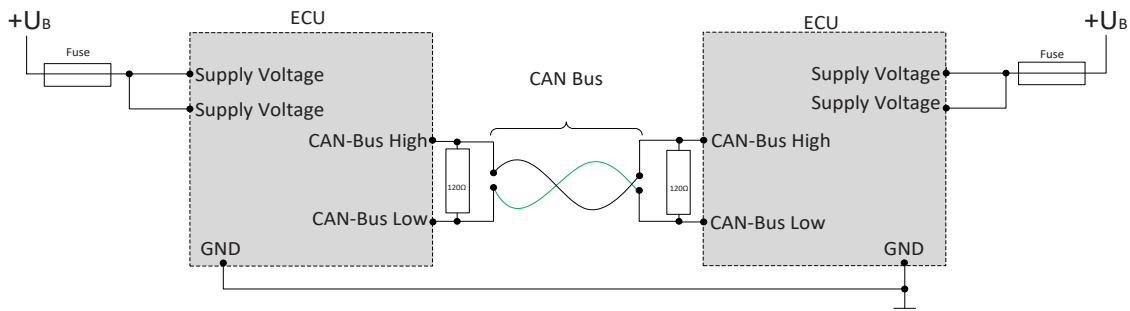

## SAFETY AND INSTALLATION INFORMATION

It is essential to read the instructions in full thoroughly before working with the device.

Please note and comply with the instructions in the operating instructions and the information in the device data sheet, see [www.mrs-electronic.com](http://www.mrs-electronic.com)

**Staff qualification:** Only staff with the appropriate qualifications may work on this device or in its proximity.

### SAFETY



**WARNING! Danger as a result of a malfunction of the entire system.**

Unforeseen reactions or malfunctions of the entire system may jeopardise the safety of people or the machine.

- Ensure that the device is equipped with the correct software and that the wiring and settings on the hardware are appropriate.



**WARNING! Danger as a result of unprotected moving components.**

Unforeseen dangers may occur from the entire system when putting the device into operation and maintaining it.

- Switch the entire system off before carrying out any work and prevent it from unintentionally switching back on.
- Before putting the device into operation, ensure that the entire system and parts of the system are safe.
- The device should never be connected or separated under load or voltage.



**CAUTION! Risk of burns from the housing.**

The temperature of the device housing may be elevated.

- Do not touch the housing and let all system components cool before working on the system.

### PROPER USE

The device is used to control or switch one or more electrical systems or sub-systems in motor vehicles and machines and may only be used for this purpose. The device may only be used in an industrial setting.



**WARNING! Danger caused by incorrect use.**

The device is only intended for use in motor vehicles and machines.

- Use in safety-related system parts for personal protection is not permitted.
- Do not use the device in areas where there is a risk of explosion.

**Correct use:**

- operating the device within the operating areas specified and approved in the associated data sheet.
- strict compliance with these instructions and no other actions which may jeopardise the safety of individuals or the functionality of the device.

**Obligations of the manufacturer of entire systems**

It is necessary to ensure that only functional devices are used. If devices fail or malfunction, they must be replaced immediately.

System developments, installation and the putting into operation of electrical systems may only be carried out by trained and experienced staff who are sufficiently familiar with the handling of the components used and the entire system.

It is necessary to ensure that the wiring and programming of the device does not lead to safety-related malfunctions of the entire system in the event of a failure or a malfunction. System behaviour of this type can lead to a danger to life or high levels of material damage.

The manufacturer of the entire system is responsible for the correct connection of the entire periphery (e.g. cable cross sections, correct selection/connection of sensors/actuators).

Opening the device, making changes to the device and carrying out repairs are all prohibited. Changes or repairs made to the cabling can lead to dangerous malfunctions. Repairs may only be carried out by MRS.

**Installation**

The installation location must be selected so the device is exposed to as low a mechanical and thermal load as possible. The device may not be exposed to any chemical loads.

Install the device in such a manner that the plugs point downwards. This means condensation can flow off the device. Single seals on the cables/leads must be used to ensure that no water gets into the device.

**Putting into operation**

The device may only be put into operation by qualified staff. This may only occur when the status of the entire system corresponds to the applicable guidelines and regulations.

### FAULT CORRECTION AND MAINTENANCE



**NOTE The device is maintenance-free and may not be opened.**

- If the device has damage to the housing, latches, seals or flat plugs, it must be taken out of operation.

Fault correction and cleaning work may only be carried out with the power turned off. Remove the device to correct faults and to clean it.

Check the integrity of the housing and all flat plugs, connections and pins for mechanical damage, damage caused by overheating, insulation damage and corrosion. In the event of faulty switching, check the software, switches and settings.

Do not clean the device with high pressure cleaners or steam jets. Do not use aggressive solvents or abrasive substances.